

# Champion™ SINK STRAINERS

## /// 245-1654 SERIES

### SPECIFICATION

Tomahawk Champion™ sink strainers are designed to prevent debris from entering a drainage system with a removable strainer basket designed to collect debris. Tomahawk sink strainers are intended to convey domestic waste from fixtures to the drain, waste and vent (DWV) system. Complies to ASME A112.18.2-2015/CSA B125.2-15.

### MATERIALS

Stainless steel

**Finish:** polished stainless steel and chrome

### FEATURES

- deep cut 14 pitch locknut threads
- fits 3-1/2" – 4" drain openings
- chrome-plated brass knob
- spring post basket
- back nut style

### DIMENSIONS

\*Tomahawk specifications in US customary units are approximate and are provided for reference only.

- |    |                    |          |
|----|--------------------|----------|
| A: | flange diameter    | 4-7/16"  |
| B: | body diameter      | 3-11/32" |
| C: | body height        | 2-3/8"   |
| D: | tailpiece          | 4"       |
| E: | tailpiece diameter | 1-1/2"   |

ITEM # SUBMITTED	_____
JOB NAME	_____
LOCATION	_____
ENGINEER	_____
CONTRACTOR	_____
PO#	_____ TAG _____



245-16541C04

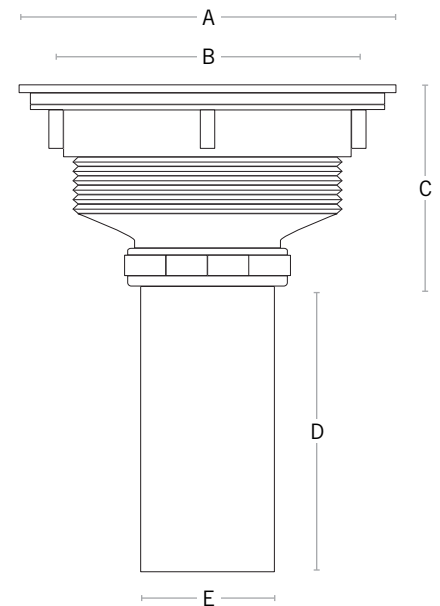

### Create Item Number

#### 245-1654A C 04

e.g. 245-16451C04: Champion™ sink strainer, stainless steel, w/ tailpiece, 1/bx

#### ADDITIONAL COMPONENTS A

0 = n/a

1 = w/ tailpiece

